



3D Surface Area and Volume

Student Activity



Name _____

Class _____

3D Surface Area and Volume

The goal of this activity is to help students make the connection between 3D objects and the 2D shapes that make up those objects. Students will “unfold” these 3D objects and find Surface Area and Volume. They will ultimately try to make a connection with how to understand these topics in IB Mathematics courses and on their final assessments.

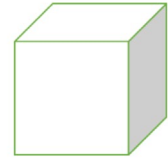

Review

In this activity, you will be finding both the Surface Area and Volume of several 3D objects. The following formulas will be useful:

Right Cylinder

Surface Area:

$$A = 2\pi rh + 2\pi r^2$$

Volume:

$$V = \pi r^2 h$$

Rectangular Prism

$$A = 2(wl + wh + lh)$$

$$V = lwh$$

Right Cone

$$A = \pi r(r + \sqrt{h^2 + r^2})$$

$$V = \frac{1}{3}\pi r^2 h$$

Sphere

$$A = 4\pi r^2$$

$$V = \frac{4}{3}\pi r^3$$

Problem 1

Before we start finding the Surface Area and Volume, let us practice unfolding 3D objects. First, the right cylinder. Discuss with a classmate what three 2D shapes you can unfold this cylinder into. Also, mention how the dimensions of the 2D shapes are found.

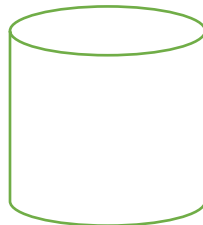

Second, the rectangular prism. Discuss with a classmate what six possible 2D shapes you can unfold this rectangular prism into. Also, mention how the dimensions of the 2D shapes are found.

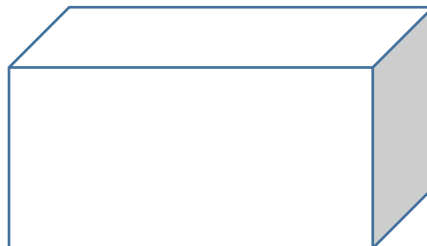



And finally, a right cone. Discuss with a classmate what two 2D shapes you can unfold this right cone into. Also, mention how the dimensions of the 2D shapes are found.

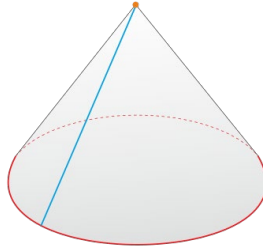

Problem 2

Find the Surface Area and Volume of each of the following 3D objects:

- (a) A right cylinder with a height of 8 in. and with a base that has a diameter of 4 in.

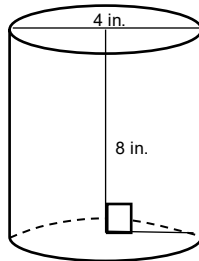

- (b) A rectangular prism with a length of 3 ft., a width of 2 ft., and a height of 30 in.

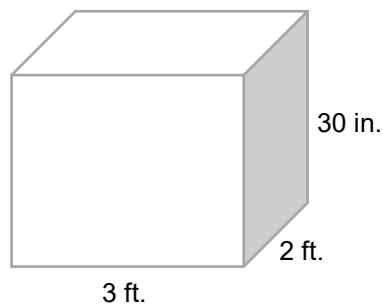

- (c) A right cone with a height of 18 cm and its base has a radius of 5 cm.

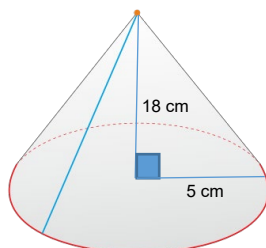



Problem 3

Given the ice cream cone below is made up of a hemisphere scoop of vanilla ice cream and a right sugar cone, find the total surface area and volume of the entire cone and ice cream.

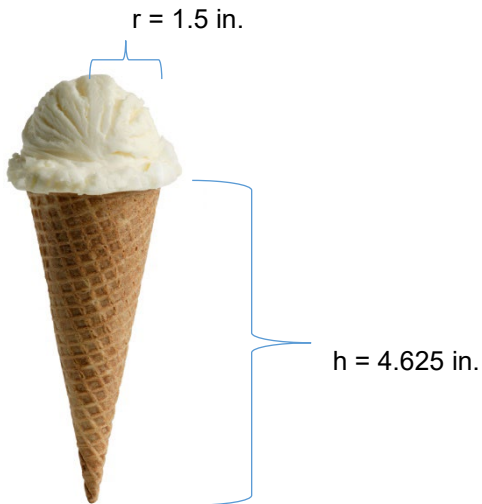

Problem 4

The water bottle below has a half of a sphere dome as the top. Find the total surface area of the entire water bottle, and if only the bottom cylindrical portion of the bottle can hold liquid, find how much it can hold.

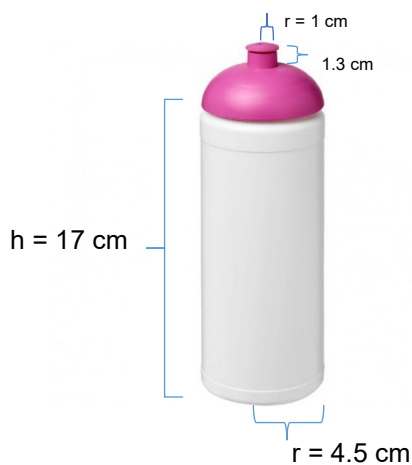



Extension

Problem 5

The entire rectangular toy chest below with a half cylindrical top needs to be stained. If the stain costs \$25.95 to cover 2 square feet of surface, find the surface area of the entire chest and the cost of the stain you will need to cover it.

