



### Math Objectives

- Students will differentiate between 2D and 3D polygons and shapes.
- Students will use formulas for both 2D shapes and 3D polygons, such as midpoint and distance, and understand how to alter them to fit the situations.
- Students will try to make a connection with how to understand these topics in IB Mathematics courses and on their final assessments.

### Vocabulary

- 2D Plane
- 3D Plane
- Midpoint
- Distance
- Right Pyramid

### About the Lesson

- This lesson is aligning with the curriculum of IB Mathematics Applications and Interpretations SL/HL and IB Mathematics Approaches and Analysis SL/HL
- This falls under the IB Mathematics Content Topic 3 Geometry and Trigonometry:
  - 3.1: (a)** The distance between two points in three-dimensional space and their midpoint
  - (b)** Volume and surface area of a right-pyramid
  - 3.2: (a)** Use of sin, cos, and tan ratios to find sides and angles of right angled triangles
  - (b)** The sine rule:  $\frac{a}{\sin A} = \frac{b}{\sin B} = \frac{c}{\sin C}$
  - (c)** The cosine rule:  $a^2 = b^2 + c^2 - 2bc \cos A$  or  $\cos A = \frac{b^2 + c^2 - a^2}{2bc}$
  - (d)** Area of a triangle in the form  $\frac{1}{2} ab \sin C$
  - 3.3: (a)** Applications of right and non-right-angled trig including Pythagorean theorem

As a result, students will:

- Apply this information to real world situations.

### Teacher Preparation and Notes.

- This activity is done with the use of the TI-84 family as an aid to the problems.

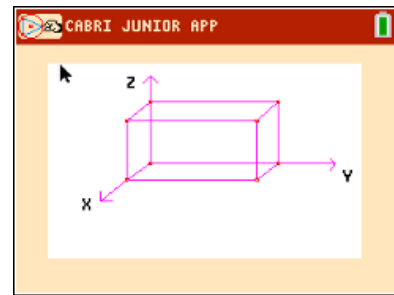

### Tech Tips:

- This activity includes screen captures taken from the TI-84 Plus CE. It is also appropriate for use with the rest of the TI-84 Plus family. Slight variations to these directions may be required if using other calculator models.
- Watch for additional Tech Tips throughout the activity for the specific technology you are using.
- Access free tutorials at <http://education.ti.com/calculators/pd/US/Online-Learning/Tutorials>

### Lesson Files:

*Student Activity*  
 2DorNot2D-Student-84CE.pdf  
 2DorNot2D-Student-84CE.doc



## Activity Materials

- Compatible TI Technologies: TI-84 Plus\*, TI-84 Plus Silver Edition\*, TI-84 Plus C Silver Edition, TI-84 Plus CE

\* with the latest operating system (2.55MP) featuring MathPrint™ functionality.

In this activity, students will differentiate between 2D and 3D polygons and shapes and how simple formulas, like midpoint and distance, alter depending on which you are dealing with. Students will then apply this knowledge to real life applications to enhance their ability to understand this math in both the two-dimensional and three-dimensional planes.

Throughout this activity, students will have to use the following formulas:

$$2D \text{ Midpoint} = \left( \frac{x_1 + x_2}{2}, \frac{y_1 + y_2}{2} \right)$$

$$2D \text{ Distance} = \sqrt{(y_2 - y_1)^2 + (x_2 - x_1)^2}$$

Other formulas to be used, but are not limited to, are the laws of sines and cosines, and simple right triangle trigonometry.

**Teacher Tip:** Although there is not a file to download to the handheld, this would be a good opportunity to introduce the ability to program formulas for students to access and use throughout this activity and beyond.

### Problem 1 – Converting from 2D to 3D

- Given the coordinates of points A and B: A(-2, 4) and B(6, 8)  
Find the midpoint of AB.

**Solution:**  $midpoint = \left( \frac{-2+6}{2}, \frac{4+8}{2} \right) = (2, 6)$

- Given the coordinates of points C and D: C(3, -1, 5) and D(-7, 3, -9)  
Discuss with a classmate what would need to change about the midpoint formula above so that you could find the midpoint of CD, then find the midpoint of CD.

**Solution:** Since points in the 3D plane are made up of x, y and z coordinates, you would add one more fraction to the formula:  $\left( \frac{z_1 + z_2}{2} \right)$

$$midpoint = \left( \frac{3+(-7)}{2}, \frac{-1+3}{2}, \frac{5+(-9)}{2} \right) = (-2, 1, -2)$$



3. Given the coordinates of points E and F: E(4, -5) and F(7, -9)  
Find the distance from E to F.

**Solution:**  $distance = \sqrt{(7 - 4)^2 + (-9 - (-5))^2} = 5$

4. Given the coordinates of points G and H: G(2, 1, -4) and H(5, -3, 8)  
Discuss with a classmate what would need to change about the distance formula above so that you could find the distance from G to H, then find the distance from G to H.

**Solution:** Since points in the 3D plane are made up of x, y and z coordinates, you would add one more squared portion under the square root symbol in the formula:  $(z_2 - z_1)^2$

$$distance = \sqrt{(5 - 2)^2 + (-3 - 1)^2 + (8 - (-4))^2} = 13$$

### Problem 2 – Combining Trig with Coordinate Geometry

Now that you have worked through altering those basic formulas for the 3D plane, let's try and use some trigonometry as well.

5. Given rectangle ABCD below, find angle ABD.

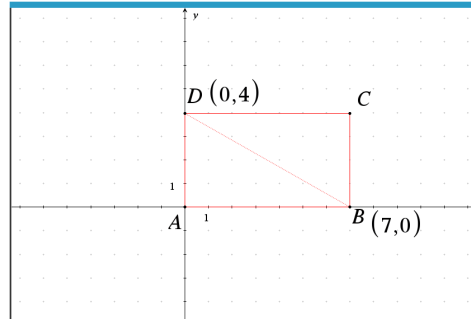

**Solution:**  $\tan^{-1}\left(\frac{4}{7}\right) \approx 29.7^\circ$

6. Given rectangle EFGH below, where M is the midpoint of GH, find angle EMF.

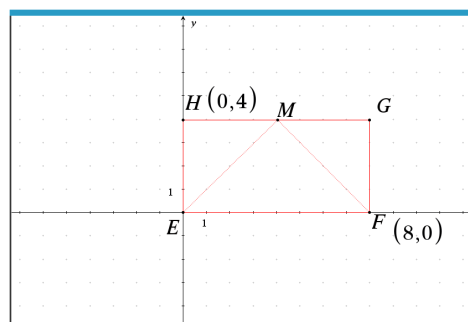



**Solution:** There are multiple ways to find this answer using pythagorean theorem, right triangle trig, and law of cosines to name a few. Here are a couple ways:

Triangles EMH and FMG are both isosceles triangles, making angles EMH and FMG both  $45^\circ$ , which makes angle EMF  $90^\circ$  as those three angles must have a sum of  $180^\circ$ , or since triangles EMH and FMG are 45-45-90 special right triangles, and their legs are 4 and 4, the hypotenuse must be  $4\sqrt{2}$ , giving you the three sides of triangle EMF and allowing you to find angle EMF using the law of cosines.

$$\text{angle EMF} = \cos^{-1} \left( \frac{(4\sqrt{2})^2 + (4\sqrt{2})^2 - 8^2}{2 \cdot (4\sqrt{2}) \cdot (4\sqrt{2})} \right) = 90^\circ$$

**Teacher Tip:** Teachers may want to extend this discussion with the students to see if they can find any other ways to find this missing angle using both trig and non-trig skills.

**Problem 3 – Shapes on the 3D plane**

Now let’s combine what you have practiced in problems 1 and 2 by placing three-dimensional shapes on a coordinate plane.

7. A marble paper weight was modelled after a right pyramid, with vertex  $T$  and a square base  $PQRS$ . The center of the base is  $U$ . The coordinates of vertex  $T$  and point  $P$  are  $(2, 3, 0)$  and  $(-3, 2, 4)$  respectively. See the diagram below.

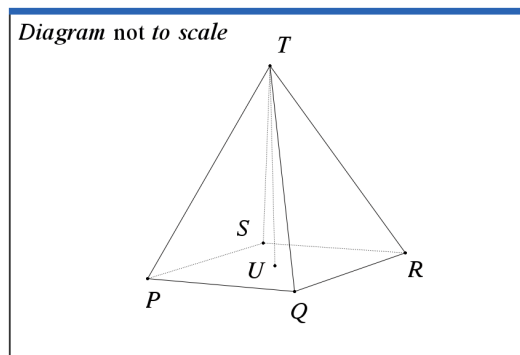

The volume of the pyramid is  $41.3 \text{ cm}^3$ .

a. Find  $PT$ .

**Solution:**  $PT = \sqrt{(2 - (-3))^2 + (3 - 2)^2 + (0 - 4)^2} \approx 6.48 \text{ cm}$



b. Given that angle  $QTR = 35^\circ$ , find  $QR$ .

**Solution:**  $QR = \sqrt{6.48^2 + 6.48^2 - 2(6.48)(6.48) \cos 35^\circ} \approx 3.90 \text{ cm}$

c. Find the height of the pyramid,  $UT$ .

**Solution:**  $Volume = \frac{1}{3}Bh$   
 $41.3 = \frac{1}{3} \cdot (3.90)^2 \cdot UT$   
 $UT = 8.16 \text{ cm}$

**Teacher Tip:** This would be a good point to go a little further with this problem. You could try adding an optimization problem to this and have the students maximize or minimize surface area using derivatives.

**Further IB Application**

Alan was injured during his climb up the mountain below. He reached a first aid outpost located at point A. Unfortunately, the outpost did not have the supplies he needed. With the help of his hiking partner, Kathy, they must get down to the main first aid outpost located at point B at ground level. Answer the questions below given that the coordinates of A and B are (5, 30, 300) and (160, 20, 0), respectively, in meters.

Thankfully, there is a straight trail from outpost A to outpost B and each set of coordinates can be described in reference to the x, y, and z-axes, where the x and y-axes are in the horizontal plane and the z-axis is in the vertical plane.

Diagram not to scale.

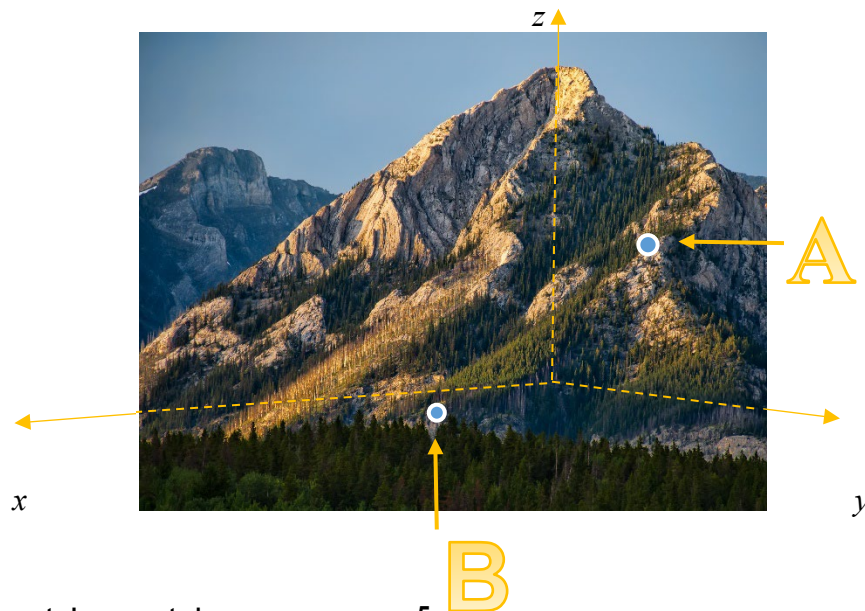



(a) Find the distance from outpost A to outpost B.

**Solution:**  $AB = \sqrt{(160 - 5)^2 + (20 - 30)^2 + (0 - 300)^2} = 337.8239 \dots \approx 338 \text{ m}$

(b) With the sun going down and the temperatures dropping, Alan and Kathy will have to make camp halfway between outpost A and B. Find the coordinates for the midpoint between outposts A and B. Call this point M.

**Solution:**  $M = \left( \frac{5+160}{2}, \frac{30+20}{2}, \frac{300+0}{2} \right) = (82.5, 25, 150)$

(c) Write down the height of point M, in meters, above the ground.

**Solution:** 150 m

**Teacher Tip:** This is a good place to have students discuss this situation and see if they can add more questions, scenarios and discussions to the problem.

**Teacher Tip:** Please know that in this activity there is a lot of time dedicated to students talking with one another and sharing their thoughts with the class. The goal here is to not only review 2D and 3D coordinate geometry, but also to generate discussion.

*\*\*Note: This activity has been developed independently by Texas Instruments and aligned with the IB Mathematics curriculum, but is not endorsed by IB™. IB is a registered trademark owned by the International Baccalaureate Organization.*