

## Transformations Reflections, and Rotations

by – Lynne B. Uebelhoer

### Activity overview

*This activity is designed to be used in a middle-school or high-school geometry classroom. An understanding of labeling points in the coordinate plane is necessary.*

### Concepts

*This is an exploration of the specific transformations: reflections and rotations.*

### Teacher preparation

*A review of the coordinate plane, quadrants, and labeling points is helpful for labeling the points as well as describing the transformations. To encourage student to describe the transformations observed concrete examples should be introduced. Using a chair with wheels, push the chair away. Ask the students to describe the change which occurred. Ask students what occurs when they look in the mirror each morning. Encourage students to develop descriptions using such terms as **flip**, **turn**, and **slide**.*

### Classroom management tips

*This activity is student-centered with the teacher role as that of facilitator. Small groups will encourage discussion regarding observations.*

### TI-Nspire Applications

*TI-Nspire, Graphs & Geometry, Notes*

*Have students open the program file and read page 1.1*

*Students are directed to draw a polygon on the grid provided on page 1.2. A possible choice is provided here as an example. Once the polygon is drawn the students are asked to label the vertices and record both the label and coordinates on their worksheet.*

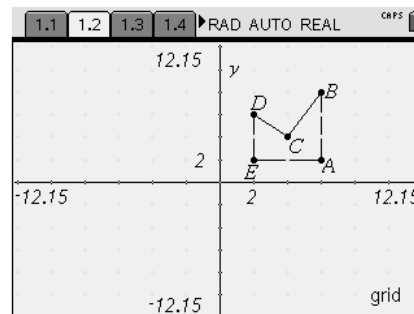

*On page 1.4 directions are given for the first transformation. A possible choice is provided here as an example. Once the polygon is drawn the students are asked to label the vertices and record both the label and coordinates on their worksheet.*

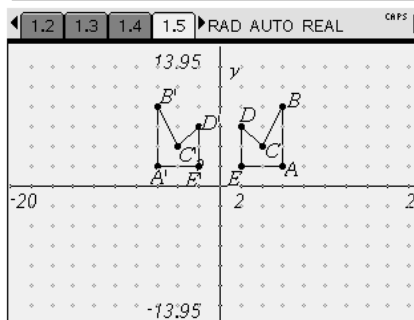

*Page 1.6 provides students an opportunity to reflect on their observations.*

*Page 1.7 and 1.9 instruct the student to continue reflecting throughout the coordinate plane. With a final stop in Quadrant IV.*

*Page 1.13 Guides student's towards a understanding of terminology presented within the activity.*

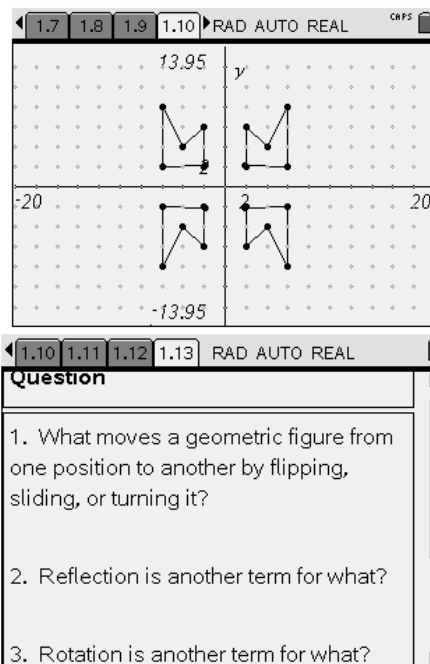

#### Assessment and evaluation

- *The handout may be collected and evaluated to determine the understanding of concepts presented in this activity.*

#### Activity extension

- *A discussion exploring the relationship between a series of reflections and rotation can illustrate the relationship between these two transformations.*

1.1 1.2 1.3 1.4 ▶ RAD AUTO REAL CRPS

This is an activity to introduce the UNIT on TRANSFORMATIONS. Refer to the instructions on your student sheet in order to have your hand-held ready for the activity as well as the questions which follow.

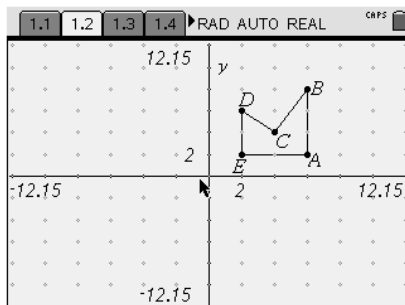

1.1 1.2 1.3 1.4 ▶ RAD AUTO REAL CRPS

Record the vertices of your polygon on your activity sheet.

1.1 1.2 1.3 1.4 ▶ RAD AUTO REAL CRPS

Once you have drawn your polygon, you are now ready to start the reflections.

The first transformation will be across the  $y$ -axis.

- 1) From the menu scroll to TRANSFORMATIONS. Arrow over and down to #2 REFLECTION.
- 2) Using the arrow highlight the polygon, it will blink. Then move the arrow to the

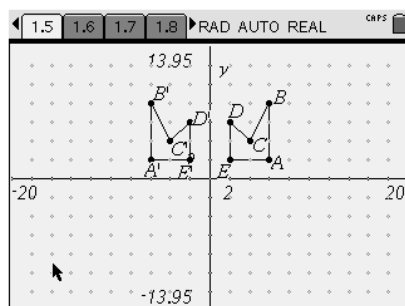

1.3 1.4 1.5 1.6 ▶ RAD AUTO REAL CRPS

**Question**

After completing the reflection, describe the new position of the polygon.

Check the coordinates of the corresponding points. What has

**Answer** ⬆

1.4 1.5 1.6 1.7 ▶ RAD AUTO REAL CRPS

Once the first transformation is completed the process will be repeated to move the polygon across the  $y$ -axis.

- 1) From the menu scroll to TRANSFORMATIONS. Arrow over and down to #2 REFLECTION.
- 2) Using the arrow highlight the polygon in the second quadrant, it will blink. Then

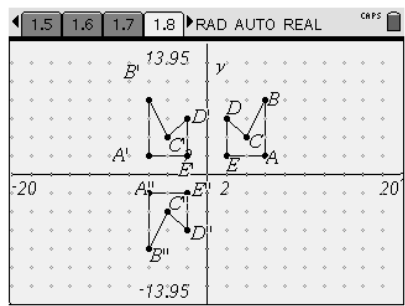

1.6 1.7 1.8 1.9 ▶ RAD AUTO REAL CRPS

Once again you will need to move your polygon across the  $y$ -axis.

From the menu scroll to TRANSFORMATIONS. Arrow over and down to #2 REFLECTION.

- 2) Using the arrow highlight the polygon in the third quadrant, it will blink. Then move the arrow to the  $y$ -axis. Hit the

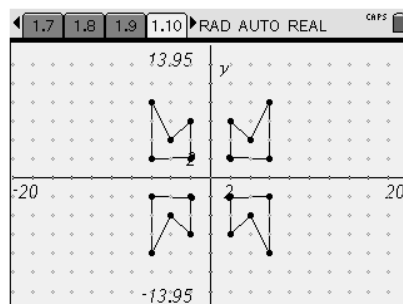

1.8 1.9 1.10 1.11 ▶ RAD AUTO REAL CRPS

**Question**

In which quadrant is your polygon?

Record the new coordinates of the vertices on your worksheet. Record your observations of the changes in

**Answer** ⬆

1.9 1.10 1.11 1.12 ▶ RAD AUTO REAL CRPS

**Question**

Once completing all transformations, transfer each figure to the coordinate plane on your worksheet. Follow the illustrations in the previous graphs to finish the figures.

**Answer** ⬆

In this activity through a series of transformations you will:

- Find the outcome of reflections across the x- and y- axis.
- Determine how a rotation may occur through reflections

Open the file Transformations: Reflections and Rotations. On page #2 you will find a coordinate grid. Under shapes choose polygon. Draw a polygon with at least three vertices. Label each of the vertices and give the coordinates. Space is provided for up to 6 vertices.

Record the vertices as well as the label:

\_\_\_\_\_ : ( \_\_\_\_\_, \_\_\_\_\_)      \_\_\_\_\_ : ( \_\_\_\_\_, \_\_\_\_\_)      \_\_\_\_\_ : ( \_\_\_\_\_, \_\_\_\_\_)  
 \_\_\_\_\_ : ( \_\_\_\_\_, \_\_\_\_\_)      \_\_\_\_\_ : ( \_\_\_\_\_, \_\_\_\_\_)      \_\_\_\_\_ : ( \_\_\_\_\_, \_\_\_\_\_)

**A)** Follow the directions within the program for moving your polygon across the y-axis. In which quadrant is the transformed polygon? \_\_\_\_\_ Describe this transformation. \_\_\_\_\_

\_\_\_\_\_

Once the transformation has been completed, record the new vertices. When labeling the new vertices use the same letters for the corresponding points adding a “ ‘ ” to each label.(i.e. A becomes A')

\_\_\_\_\_ : ( \_\_\_\_\_, \_\_\_\_\_)      \_\_\_\_\_ : ( \_\_\_\_\_, \_\_\_\_\_)      \_\_\_\_\_ : ( \_\_\_\_\_, \_\_\_\_\_)  
 \_\_\_\_\_ : ( \_\_\_\_\_, \_\_\_\_\_)      \_\_\_\_\_ : ( \_\_\_\_\_, \_\_\_\_\_)      \_\_\_\_\_ : ( \_\_\_\_\_, \_\_\_\_\_)

What happened to the corresponding x- and y- coordinates? \_\_\_\_\_

\_\_\_\_\_

**B)** Follow the directions within the program for moving your polygon across the x-axis. In which quadrant is the transformed polygon? \_\_\_\_\_ Describe this transformation. \_\_\_\_\_

\_\_\_\_\_

Once the transformation has been completed, record the new vertices. When labeling the new vertices use the same letters for the corresponding points adding a “ ‘ “ to each label.(i.e. A’ becomes A’’)

\_\_\_\_\_ : ( \_\_\_\_\_, \_\_\_\_\_)      \_\_\_\_\_ : ( \_\_\_\_\_, \_\_\_\_\_)      \_\_\_\_\_ : ( \_\_\_\_\_, \_\_\_\_\_)  
 \_\_\_\_\_ : ( \_\_\_\_\_, \_\_\_\_\_)      \_\_\_\_\_ : ( \_\_\_\_\_, \_\_\_\_\_)      \_\_\_\_\_ : ( \_\_\_\_\_, \_\_\_\_\_)

What happened to the corresponding x- and y- coordinates? \_\_\_\_\_

**C)** Follow the directions within the program for moving your polygon across the y-axis. In which quadrant is the transformed polygon? \_\_\_\_\_ Describe this transformation. \_\_\_\_\_

Once the transformation has been completed, record the new vertices. When labeling the new vertices use the same letters for the corresponding points adding a “ ‘ “ to each label.(i.e. A’ becomes A’’)

\_\_\_\_\_ : ( \_\_\_\_\_, \_\_\_\_\_)      \_\_\_\_\_ : ( \_\_\_\_\_, \_\_\_\_\_)      \_\_\_\_\_ : ( \_\_\_\_\_, \_\_\_\_\_)  
 \_\_\_\_\_ : ( \_\_\_\_\_, \_\_\_\_\_)      \_\_\_\_\_ : ( \_\_\_\_\_, \_\_\_\_\_)      \_\_\_\_\_ : ( \_\_\_\_\_, \_\_\_\_\_)

What happened to the corresponding x- and y- coordinates? \_\_\_\_\_

**D)** What would occur if you were to complete one more transformation of your polygon? \_\_\_\_\_

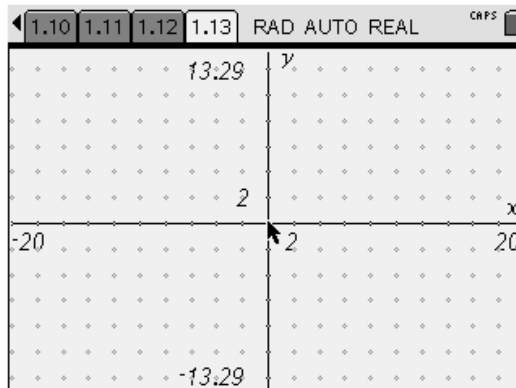

**E)**